

Category 4, EN 954-1 PNOZ X3.1

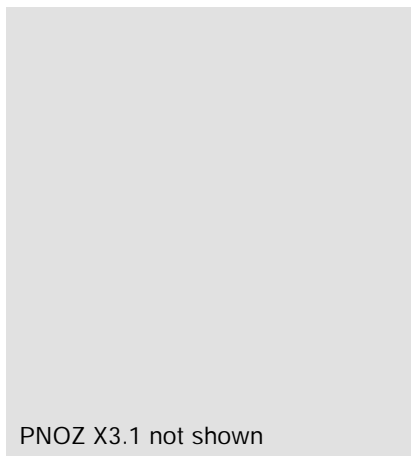



Emergency stop relay and safety gate monitor in accordance with VDE 0113-1, 11/98, EN 60204-1, 12/97 and IEC 204-1, 11/98

Features

- Monitored manual or automatic reset can be selected
- 1 semiconductor output (K1/K2)
- Each AC unit can be operated with 24 VDC
- Safety gate function with N/C-N/O combination
- Only dual-channel operation will detect shorts across the input contacts
- Input status display

Approvals

	PNOZ X3.1
	Pending
	●
	●

Technical Details	PNOZ X3.1
Electrical data	
Supply voltage	AC: 230, 240 V DC: 24 V
Tolerance	85 ... 110 %
Power Consumption	Approx. 2.5 W/5 VA
Voltage and current at the input, reset circuits and feedback control loop	24 V DC, 35 mA
Switching capability in accordance with EN 60947-4-1, 01/92	AC1: 240 V/8 A/2000 VA DC1: 24 V/8 A/200 W
EN 60947-5-1, 11/97 (DC13: 6 cycles/min)	AC15: 230 V/5 A; DC13: 24 V/6A
Output contacts	3 safety contacts (N/O), 1 auxiliary contact (N/C)
Contact fuse protection in accordance with EN 60947-5-1, 11/97	10 A quick or 6 A slow
Semiconductor outputs	24 V DC/20 mA, short-circuit protected
External supply voltage	24 V DC ±20 %
Times	
Delay-on energisation	Monitored manual reset: max. 100 ms Automatic reset: max. 0.3 s
Delay-on de-energisation	With E-STOP: max. 80 ms With power failure: max. 1 s
Recovery time	Approx. 1 s
Simultaneity channel 1/2	∞
Supply interruption before de-energisation	Approx. 25 ms
Environmental data	
Ambient temperature	-25 ... +55 °C
Mechanical data	
Maximum cross section of external conductor	2 x 1.5 mm ² or 1 x 2.5 mm ² Single-core or multi-core with crimp connector
Dimensions (H x W x D)	87 x 45 x 121 mm
Weight	420 g

Description

- 45 mm P-97 housing, DIN-Rail mounting
- Positive-guided relay outputs:
 - 3 safety contacts (N/O)
 - 1 auxiliary contact (N/C)
- Connections for
 - E-STOP button
 - safety gate limit switch
 - reset button
- Semiconductor output signals ready for operation
- LEDs for switching status of the input circuits, channel 1/2 and power
- Increase in the number of safety contacts available by connecting expander modules

Operating Modes

- Single-channel operation
- Dual-channel operation
- Automatic reset
- Monitored manual reset

Category 4, EN 954-1 PNOZ X3.1

Internal wiring diagram

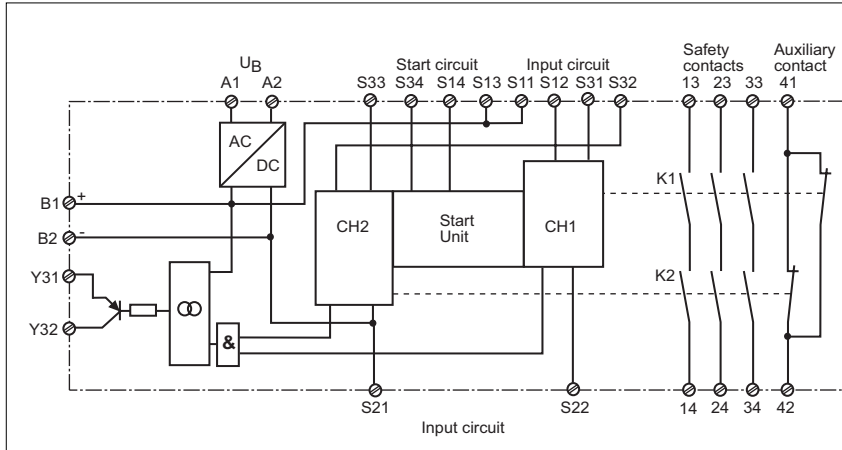

- Example 5
Dual-channel safety gate control with monitored manual reset.

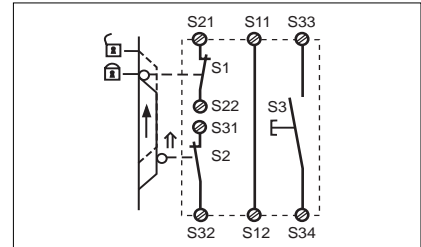

- Example 6
Dual-channel safety gate control with automatic reset.

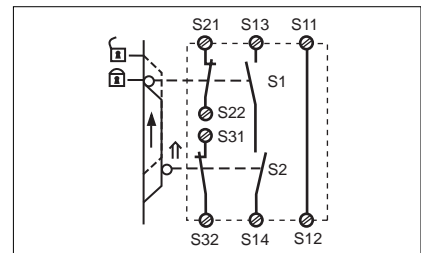

External wiring

- Example 1
Single-channel E-STOP wiring with automatic reset.

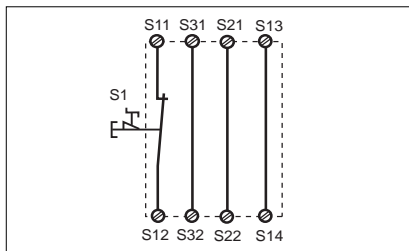

- Example 3
Dual-channel E-STOP wiring with monitored manual reset.

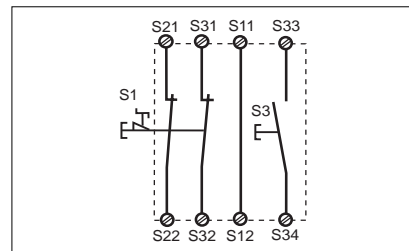

- Example 2
Single-channel E-STOP wiring with monitored manual reset.

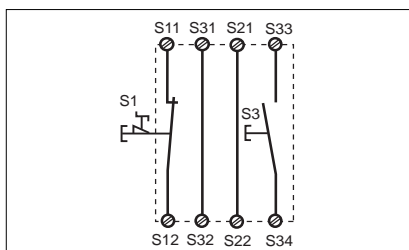

- Example 4
Single-channel safety gate control with monitored manual reset.

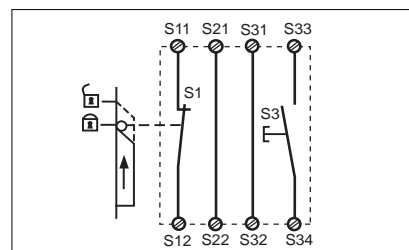

- Key

- S1/S2: E-STOP or safety gate switch
- S3: Reset button
- ↑ Switch operated
- ⏏ Gate open
- ⏏ Gate closed

Category 4, EN 954-1 PNOZ X3.1

● Increase in safety contacts
The number of output contacts can be increased by using expander modules or relays/contactors with positive-guided contacts.

– Operation with automatic reset.

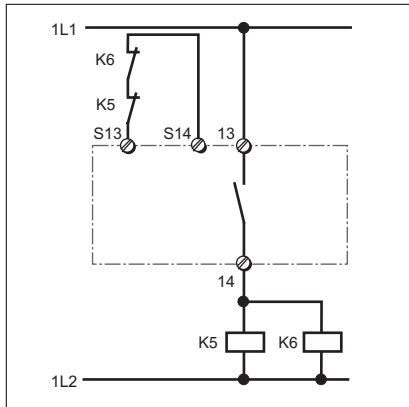

– Operation with monitored manual reset.

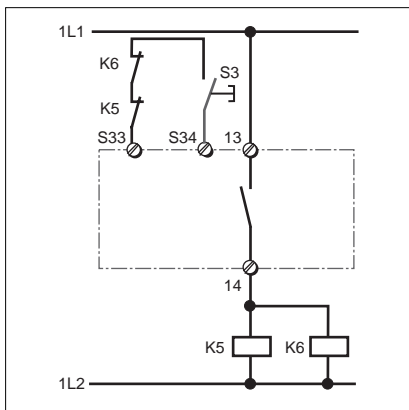

Category 4, EN 954-1 PNOZ X3.1

General Technical Details

Unless stated otherwise in the technical details for the specific unit.

Electrical data

AC Frequency Range	50 ... 60 Hz
DC residual ripple	160 %
Contact material	AgSnO ₂
Continuous duty	100 %

Environmental data

EMC	EN 50081-1, 01/92, EN 50082-2, 08/97
Vibration in accordance with EN 60068-2-6, 04/95	Frequency: 10 ... 55 Hz, Amplitude: 0.35 mm
Climatic suitability	DIN IEC 60068-2-3, 12/86
Airgap creepage	DIN VDE 0110-1, 04/97
Ambient temperature	-10 ... +55 °C
Storage temperature	-40 ... +85 °C

Mechanical data

Torque setting for connection terminals	0.6 Nm (screws)
Mounting position	Any
Housing material	Thermoplastic Noryl SE 100
Protection types	Mounting: IP 54 Housing: IP 40 Terminals: IP 20